



深圳秋田微电子有限公司
SHENZHEN AV-DISPLAY CO.,LTD.

深圳市秋田微电子有限公司
地址：深圳市龙岗区横岗镇荷坳金源工业区金源路 39 号

电话:(086)0755-88860696 传真: (086)0755 -26911092
网址: [Http://www.av-display.com.cn](http://www.av-display.com.cn)

SHENZHEN AV-DISPLAY CO.,LTD
Address: No. 39, Jinyuan Road, He'ao Jinyuan industrial zone, Henggang Town, Long Gang district, Shenzhen, China
TEL: (086)0755-88860696 FAX: (086)0755-26911092
[Http://www.av-display.com.cn](http://www.av-display.com.cn)

**SPECIFICATION
FOR
LCM MODULE**

**MODULE NO.: APG320240B06-BIW-R
DOC.REVISION 03**

AVD	PREPARED BY	CHECKED BY	APPROVED BY
SIGNATURE			
DATE			

CUSTOMER APPROVAL	SIGNATURE	DATE

This Specification is subject to change without prior notice. Please contact SHENZHEN AV-DISPLAY CO.,LTD to confirm the latest revision.

If there is no special request from customer, AVD will not reserve the tooling of the product under the following conditions:

1. there is no response from customer in two years after AVD submit the samples;
2. there is no order in two years after the latest mass production and correlated data(include quality record) will be reserved one year more after tooling was discarded.



深圳秋田微电子有限公司
SHENZHEN AV-DISPLAY CO.,LTD.

DOCUMENT REVISION HISTORY

Version	DATE	DESCRIPTION	CHANGED BY
00	Oct-17-2008	First issue	Rory
01	Sep-14-2009	Update format Remove PIN HEADER	Jequil
02	Nov-10-2010	Modify 5. Pin description	Wqy
03	Dec-21-2010	Change Operating&Storage temp	



CONTENTS

1. Functions & Features	1
2. Mechanical specifications	1
3. Block diagram	1
4. Dimensional Outline	2
5. Pin description	3
6. Maximum absolute limit	3
7. Electrical characteristics	3
8. Timing Characteristics	4/5
9. The /RES (RESET) Terminal	5
10. Control and display command	6
11. Backlight Characteristics	7
12. Electrol-Optical characteristics	7
13. Precaution for using LCD/LCM	8~9
14. LCM test criteria	10-18



1. FUNCTIONS & FEATURES

- | | |
|---|--------------------------------------|
| 1.1. Format | : 320x240dots |
| 1.2. LCD mode | : STN / Negative/Transmissive / Blue |
| 1.3. Viewing direction | : 6 o'clock |
| 1.4. Driving scheme | : 1/240 Duty cycle, 1/12 Bias |
| 1.5. Power supply voltage(V _{DD}) | : 5.0V |
| 1.6. LCD driving voltage | : 23.8V(Reference voltage) |
| 1.7. Operation temp | : -20~70°C |
| 1.8. Storage temp | : -30~80°C |
| 1.9. Backlight color | : Edge White |

2. MECHANICAL SPECIFICATIONS

- | | |
|-------------------|------------------------------------|
| 2.1. Module size | : 160.0mm(L)*109.0mm(W)*12.7 mm(H) |
| 2.2. Viewing area | : 123.0mm(L)*92.1mm(W) |
| 2.3. Dot pitch | : 0.36mm(L)*0.36mm(W) |
| 2.4. Dot size | : 0.33mm(L)*0.33mm(W) |
| 2.5. Weight | : Approx. |

3. BLOCK DIAGRAM

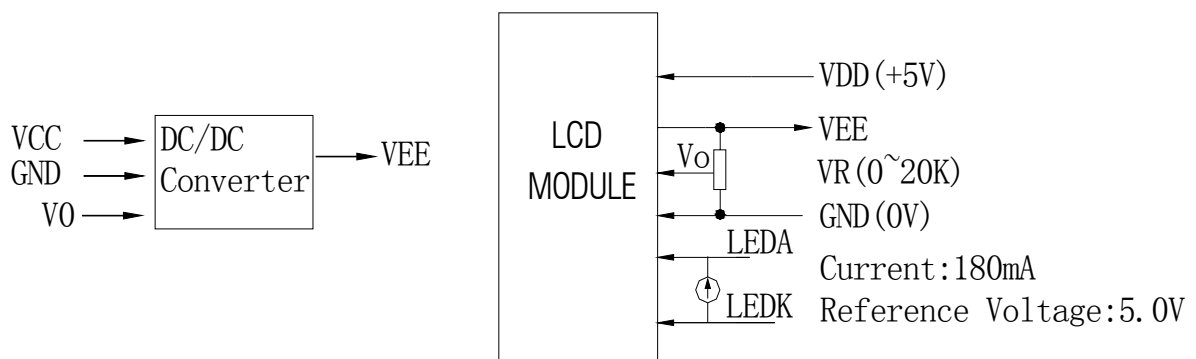
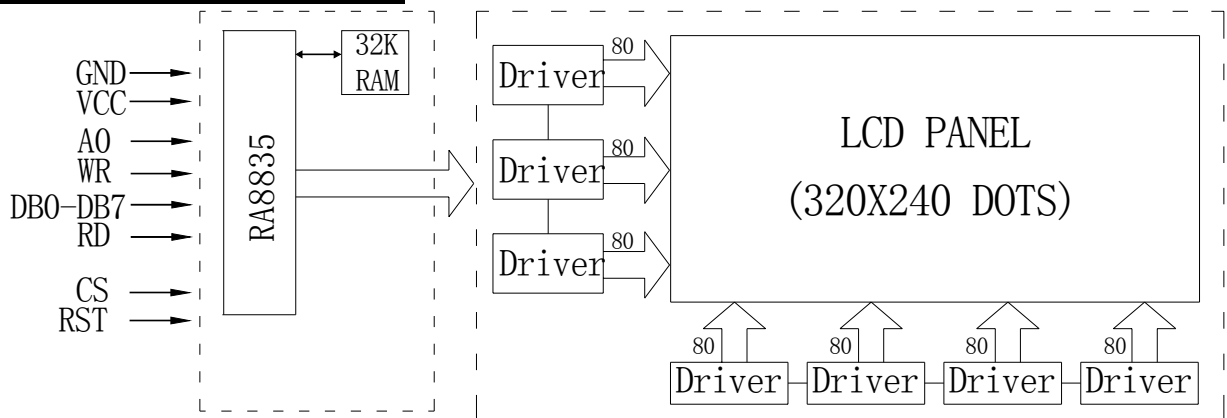

Figure 1. Block diagram



4. DIMENSIONAL OUTLINE

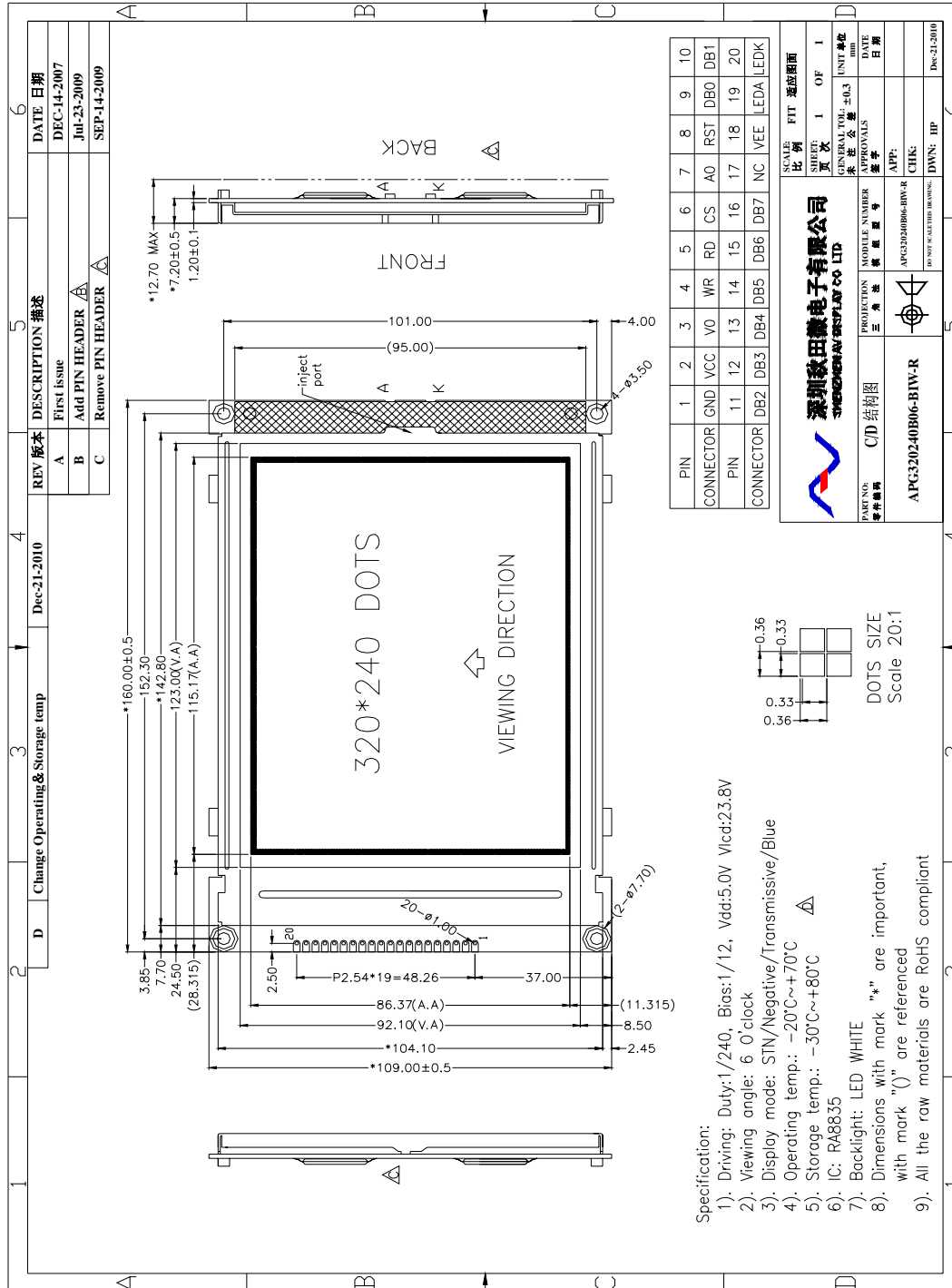

Figure 2. Dimensional outline



5. PIN DESCRIPTION

No.	Symbol	Function
1	GND	GND(0V)
2	VCC	Power supply for the logic (+5.0V)
3	V0	Power supply for the LCD drive
4	WR	8080 family: Write signal . (active in low)
5	RD	8080 family: Read signal . (active in low)
6	CS	Chip enable signal (active in low)
7	A0	Register selection (when “RD=A0=1”: Command write; when “RD=1 ;A0=0”: Display data and parameter write)
8	RST	Reset signal(active in low)
9-16	DB0~DB7	Data bus line
17	NC	No connection
18	VEE	Output of supply negative voltage by the DC-DC converter on the module
19	LEDA	Power supply for LED (Current:180mA, reference voltage:5.0V)
20	LEDK	Power supply for LED(0V)

6. MAXIMUM ABSOLUTE LIMIT

Item	Symbol	MIN	MAX	Unit
Supply Voltage for Logic	V _{DD}	-0.3	7.0	V
Supply Voltage for LCD	V ₀	V _{DD} -29.0	V _{DD} +0.3	V
Input Voltage	V _{in}	-0.3	V _{DD} +0.3	V
Supply Current for Backlight	I _F (Ta = 25°C)	---	205	mA
Reverse Voltage for Backlight	V _R (Ta = 25°C)	---	0.8	V
Operating Temperature	Top	-20	70	°C
Storage Temperature	T _{st}	-30	80	°C

7. ELECTRICAL CHARACTERISTICS

Item	Symbol	Condition	Min	Typ	Max	Unit
Supply Voltage for Logic	V _{DD} -V _{SS}	Ta = 25°C	4.75	5.0	5.25	V
Input High Voltage	V _{IH}	Ta = 25°C	---	0.75 V _{DD}	V _{DD}	V
Input Low Voltage	V _{IL}	Ta = 25°C	0	0.25 V _{DD}	---	V
Output High Voltage	V _{OH}	Ta = 25°C	V _{DD} -0.4	---	---	V
Output Low Voltage	V _{OL}	Ta = 25°C	---	---	V _{SS} +0.4	V
Supply Current	I _{DD}	Ta = 25°C	---	---	60	mA



8. TIMING CHARACTERISTICS

8080 family Interface Timing

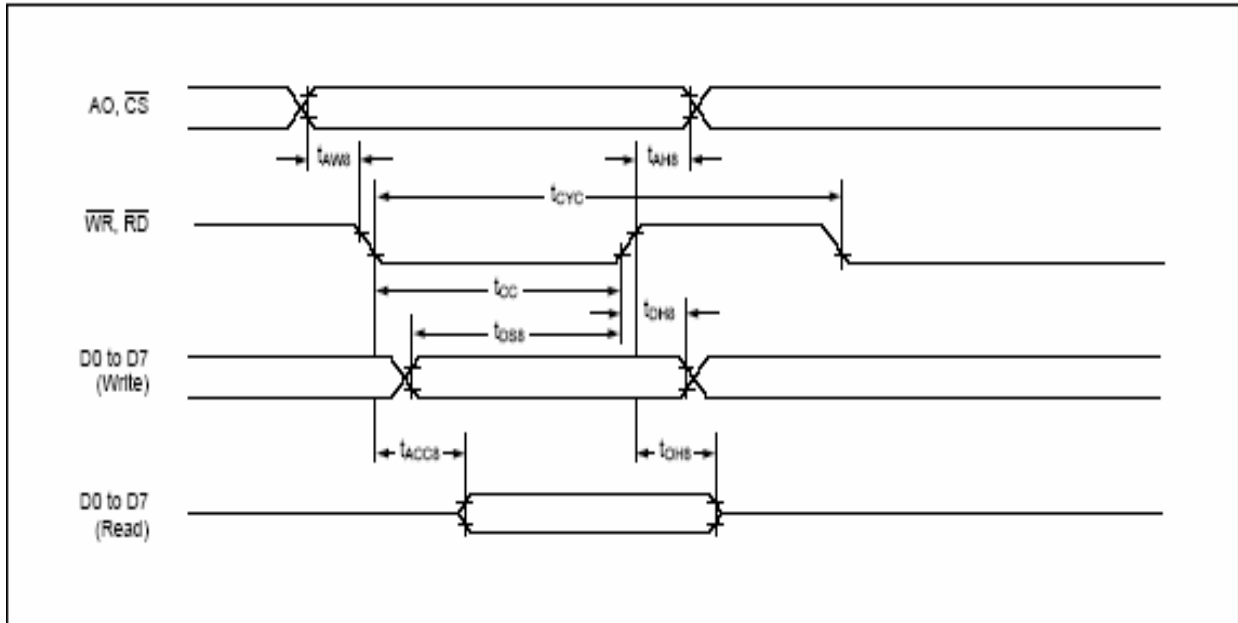

Signal	Symbol	Parameter	VDD = 4.5 to 5.5V		VDD = 2.7 to 4.5V		Unit	Condition
			min	max	min	max		
AO, \overline{CS}	t_{AH8}	Address hold time	10	—	10	—	ns	CL = 100 pF
	t_{AW8}	Address setup time	0	—	0	—	ns	
$\overline{WR}, \overline{RD}$	t_{CYC}	System cycle time	See note	—	See note	—	ns	
	t_{OC}	Strobe pulsewidth	120	—	150	—	ns	
D0 to D7	t_{DS8}	Data setup time	120	—	120	—	ns	
	t_{DH8}	Data hold time	5	—	5	—	ns	
	t_{ACC8}	\overline{RD} access time	—	50	—	80	ns	
	t_{OH8}	Output disable time	10	50	10	55	ns	

Note: For memory control and system control commands:

$$t_{CYC8} = 2t_c + t_{OC} + t_{CEA} + 75 > t_{ACV} + 245$$

For all other commands:

$$t_{CYC8} = 4t_c + t_{OC} + 30$$



6800 family Interface Timing

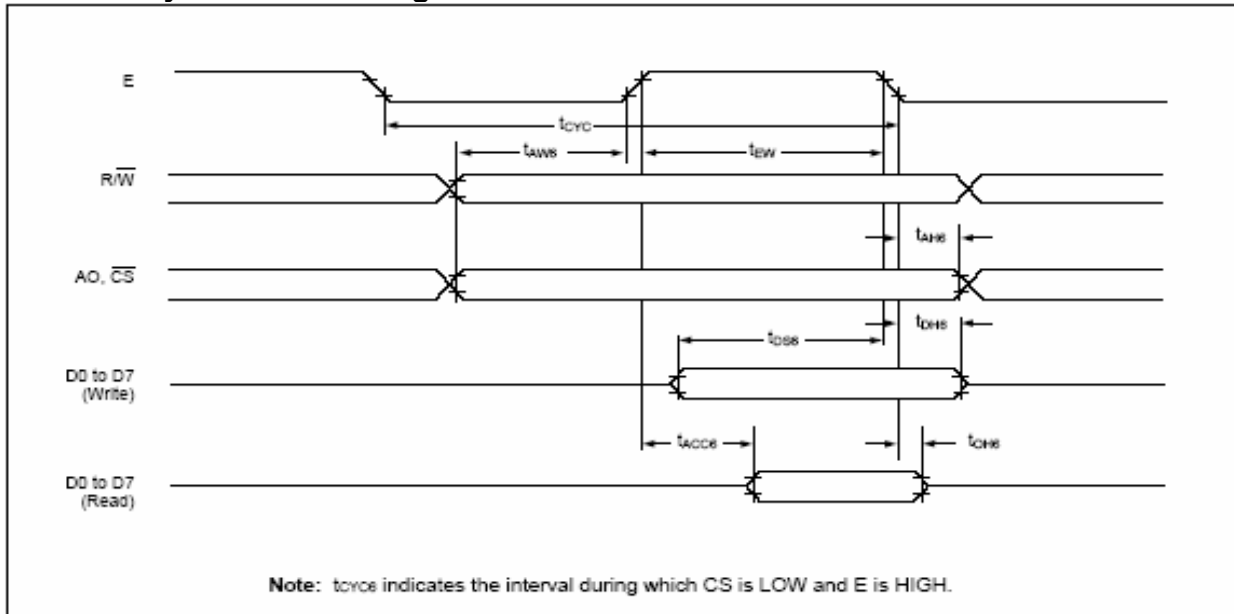

Signal	Symbol	Parameter	VDD = 4.5 to 5.5V		VDD = 2.7 to 4.5V		Unit	Condition
			min	max	min	max		
AO, CS, R/W	tCYC6	System cycle time	See note	—	See note	—	ns	CL = 100 pF
	tAW6	Address setup time	0	—	10	—	ns	
	tAH6	Address hold time	0	—	0	—	ns	
D0 to D7	tDS6	Data setup time	100	—	120	—	ns	
	tDH6	Data hold time	0	—	0	—	ns	
	tOH6	Output disable time	10	50	10	75	ns	
	tACC6	Access time	—	85	—	130	ns	
E	tEW	Enable pulsewidth	120	—	150	—	ns	

Note: For memory control and system control commands:

$$t_{CYC6} = 2t_c + t_{EW} + t_{CEA} + 75 > t_{ACV} + 245$$

For all other commands:

$$t_{CYC6} = 4t_c + t_{EW} + 30$$

9. The /RES (RESET) Terminal

(V_{DD} = 5.0V, T_a = 25°C)

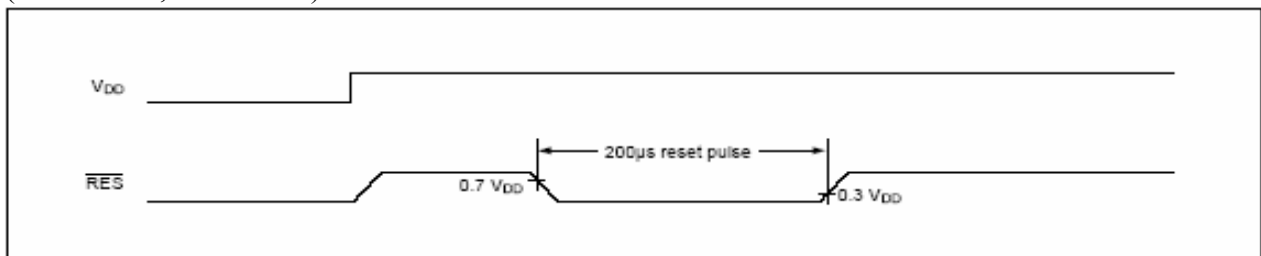



10. CONTROL AND DISPLAY COMMAND

Class	Command	Code										Hex	Command Description	
		RD	WR	A0	D7	D6	D5	D4	D3	D2	D1			D0
System Control	SYSTEM SET	1	0	1	0	1	0	0	0	0	0	0	40	Initialize device and display
	SLEEP IN	1	0	1	0	1	0	1	0	0	1	1	53	Enter standby mode
Display Control	DISPLAY ON/OFF	1	0	1	0	1	0	1	1	0	0	D	58, 59	Enable and disable display and display flashing
	SCROLL	1	0	1	0	1	0	0	0	1	0	0	44	Set display start address and display regions
	CSRFORM	1	0	1	0	1	0	1	1	1	0	1	5D	Set cursor type
	CGRAM ADR	1	0	1	0	1	0	1	1	1	0	0	5C	Set start address of character generator RAM
	CSRDIR	1	0	1	0	1	0	0	1	1	CD 1	CD 0	4C to 4F	Set direction of cursor movement
	HDOT SCR	1	0	1	0	1	0	1	1	0	1	0	5A	Set horizontal scroll position
	OVLAY	1	0	1	0	1	0	1	1	0	1	1	5B	Set display overlay format
Drawing Control	CSRW	1	0	1	0	1	0	0	0	1	1	0	46	Set cursor address
	CSRR	1	0	1	0	1	0	0	0	1	1	1	47	Read cursor address
Memory Control	MWRITE	1	0	1	0	1	0	0	0	0	1	0	42	Write to display memory
	MREAD	1	0	1	0	1	0	0	0	0	1	1	43	Read from display memory

Notes:

1. In general, the internal registers of the RA8835 series are modified as each command parameter is input. However, the microprocessor does not have to set all the parameters of a command and may send a new command before all parameters have been input. The internal registers for the parameters that have been input will have been changed but the remaining parameter registers are unchanged. 2-byte parameters (where two bytes are treated as 1 data item) are handled as follows:

- a. CSRW, CSRR: Each byte is processed individually. The microprocessor may read or write just the low byte of the cursor address.
- b. SYSTEM SET, SCROLL, CGRAM ADR: Both parameter bytes are processed together the command is changed after half of the parameter has been input, the single byte ignored.

2. APL and APH are 2-byte parameters, but are treated as two 1-byte parameters.



11.BACK LIGHT CHARACTERISTICS

Ta = 25°C

LCD Module with White Backlight

ELECTRICAL RATINGS

Item	Symbol	min	typ	max	Unit	Condition
Forward Voltage	Vf	3.8	4.0	4.2	V	If=180mA
Reverse Current	Ir		15		mA	Vr=0.8 V
Luminance(Without LCD)	Lv	370	430		cd/m ²	If= 180 mA
Wave length(Without LCD)	X Y	X=0.26 Y=0.27		X=0.30 Y=0.31		If= 180mA

Note:when the temperature exceed 25°C, the approved current decrease rate for Backlight change as the temperature increase is: -0.36x12mA/°C(below 25°C, the current refer to constant, which would not change with temperature).

12. ELECTRO-OPTICAL CHARACTERISTICS

(Ta = 25°C)

Item	Symbol	Condition	Min	Typ	Max	Unit
Operating Voltage	Vop	Ta = -20°C	23.9	24.3	24.7	V
		Ta = 25°C	23.4	23.8	24.2	
		Ta = 70°C	22.9	23.3	23.7	
Response time	Tr	Ta = 25°C	---	185	---	ms
	Tf		---	200	---	ms
Contrast	Cr	Ta = 25°C θx=θy=0	---	4	---	---
Viewing angle range	θx	Cr≥2	-40	---	+40	deg
	θy		-45	---	+30	deg

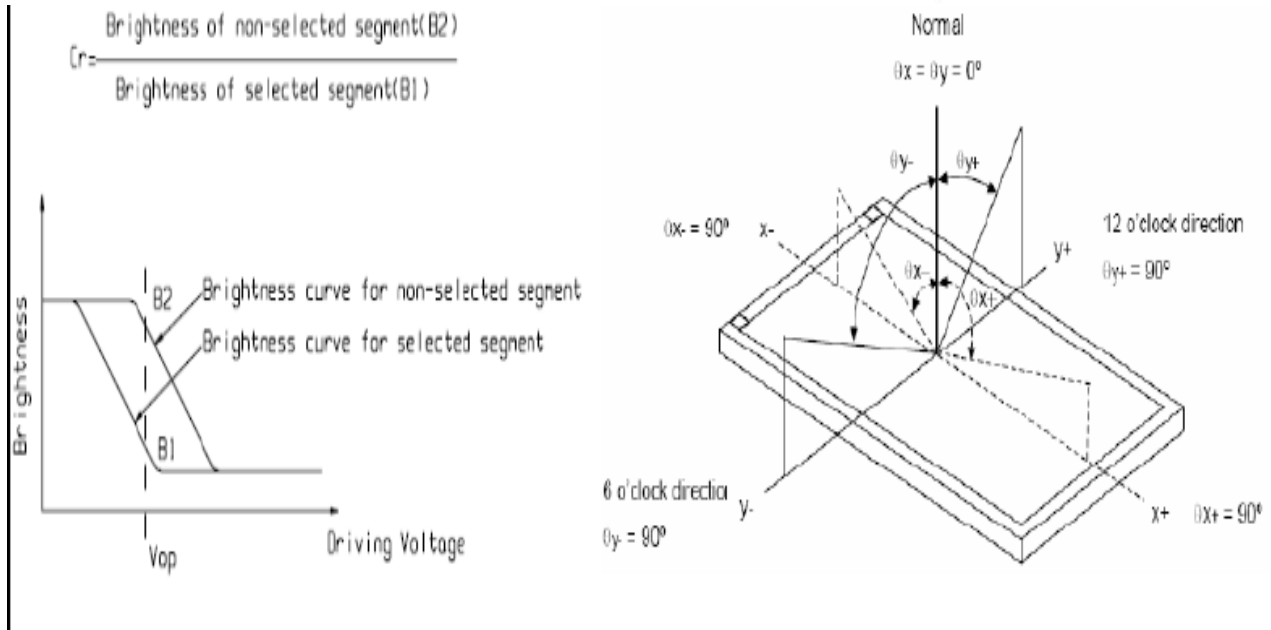

13. PRECAUTION FOR USING LCD/LCM

LCD/LCM is assembled and adjusted with a high degree of precision. Do not attempt to make any alteration or modification. The followings should be noted.

General Precautions:

1. LCD panel is made of glass. Avoid excessive mechanical shock or applying strong pressure onto the surface of display area.
2. The polarizer used on the display surface is easily scratched and damaged. Extreme care should be taken when handling. To clean dust or dirt off the display surface, wipe gently with cotton, or other soft material soaked with isopropyl alcohol, ethyl alcohol or trichlorotrifluoroethane, do not use water, ketone or aromatics and never scrub hard.
3. Do not tamper in any way with the tabs on the metal frame.
4. Do not make any modification on the PCB without consulting AVD.
5. When mounting a LCM, make sure that the PCB is not under any stress such as bending or twisting. Elastomer contacts are very delicate and missing pixels could result from slight dislocation of any of the elements.
6. Avoid pressing on the metal bezel, otherwise the elastomer connector could be deformed and lose contact, resulting in missing pixels and also cause rainbow on the display.
7. Be careful not to touch or swallow liquid crystal that might leak from a damaged cell. Any liquid crystal adheres to skin or clothes, wash it off immediately with soap and water.



Static Electricity Precautions:

1. CMOS-LSI is used for the module circuit; therefore operators should be grounded whenever he/she comes into contact with the module.
2. Do not touch any of the conductive parts such as the LSI pads; the copper leads on the PCB and the interface terminals with any parts of the human body.
3. Do not touch the connection terminals of the display with bare hand; it will cause disconnection or defective insulation of terminals.
4. The modules should be kept in anti-static bags or other containers resistant to static for storage.
5. Only properly grounded soldering irons should be used.
6. If an electric screwdriver is used, it should be grounded and shielded to prevent sparks.
7. The normal static prevention measures should be observed for work clothes and working benches.
8. Since dry air is inductive to static, a relative humidity of 50-60% is recommended.

Soldering Precautions:

1. Soldering should be performed only on the I/O terminals.
2. Use soldering irons with proper grounding and no leakage.
3. Soldering temperature: 270~300°C
4. Soldering time: 2 to 3 second.
5. Use eutectic solder with resin flux filling.
6. If flux is used, the LCD surface should be protected to avoid spattering flux.
7. Flux residue should be removed.

Operation Precautions:

1. The viewing angle can be adjusted by varying the LCD driving voltage V_o .
2. Since applied DC voltage causes electro-chemical reactions, which deteriorate the display, the applied pulse waveform should be a symmetric waveform such that no DC component remains. Be sure to use the specified operating voltage.
3. Driving voltage should be kept within specified range; excess voltage will shorten display life.
4. Response time increases with decrease in temperature.
5. Display color may be affected at temperatures above its operational range.
6. Keep the temperature within the specified range usage and storage. Excessive temperature and humidity could cause polarization degradation, polarizer peel-off or generate bubbles.
7. For long-term storage over 40°C is required, the relative humidity should be kept below 60%, and avoid direct sunlight.

Limited Warranty

AVD LCDs and modules are not consumer products, but may be incorporated by AVD's customers into consumer products or components thereof, AVD does not warrant that its LCDs and components are fit for any such particular purpose.

1. The liability of AVD is limited to repair or replacement on the terms set forth below. AVD will not be responsible for any subsequent or consequential events or injury or damage to any personnel or user including third party personnel and/or user. Unless otherwise agreed in writing between AVD and the customer, AVD will only replace or repair any of its LCD which is found



defective electrically or visually when inspected in accordance with AVD general LCD inspection standard . (Copies available on request)

2. No warranty can be granted if any of the precautions state in handling liquid crystal display above has been disregarded. Broken glass, scratches on polarizer mechanical damages as well as defects that are caused accelerated environment tests are excluded from warranty.
3. In returning the LCD/LCM, they must be properly packaged; there should be detailed description of the failures or defect.

14. LCM test criteria

1. Objective

The LCM test criteria are set to formalize AVD's LCM quality standards with reference to those of the customer for inspection, release and acceptance of finished LCM products in order to guarantee the quality required by the customer.

2. Scope

The criteria are applicable to all the LCM products manufactured by AVD, either supplied alone or embedded in or integrated with other components.

3. Inspection Apparatuses

Function testers, vernier calipers, microscopes, magnifiers, ESD wrist straps, finger cots, labels, ovens for high-low temperature tests, refrigerators, constant voltage power supply (DC) , desk lamps, etc.

4. Sampling Plan and Reference Standards

4.1.1 According to GB/T 2828.1---2003/ISO2859-1:1999, single sampling under formal inspection and the general inspection level II applies.

Item of Inspection	Sampling Rate	AQL Assessment
Cosmetic	II Single Sampling	MA=0.4 MI=1.5
Mechanical	N=3	C=0
Functional	II Single Sampling	MA=0.4 MI=1.5

4.1.2 GB/T 2828.1---2003/ISO2859-1:1999, sampling procedures and tables for batch inspection.



4.1.3 GB/T 1619.96 Test Methods for TN LCD.

4.1.4 GB/T 12848.91 General Specifications for STN LCD.

4.1.5 GB2421-89 Basic Environmental Test Procedures for Electrical and Electronic Products

4.1.6 IPC-A-610C Acceptance Condition for Electrical Assemblies.

5. Inspection Conditions and Inspection Reference

5.1 Cosmetic inspection: shall be done normally at $25\pm 5^{\circ}\text{C}$ of the ambient temperature and $45\pm 20\%$ RH of relative humidity, under the ambient luminance greater than $300\text{cd}/\text{cm}^2$ and at the distance of 30cm apart between the inspector's eyes and the LCD panel and normally in reflected light. For back-lit LCMs, cosmetic inspection shall be done under the ambient luminance less than $100\text{cd}/\text{cm}^2$ with the backlight on.

5.2 The LCM shall be tested at the angle of 45° , left and right, and $0-45^{\circ}$, top and bottom (for STN LCM, at 20° - 55°).

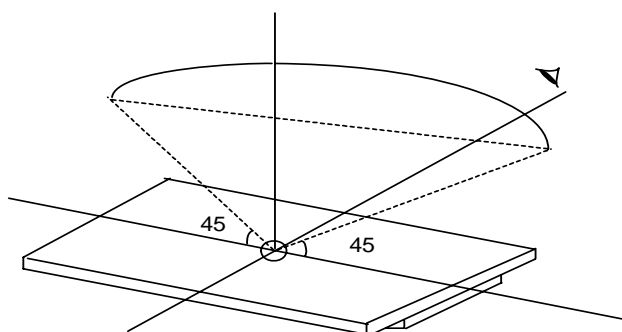

5.3 Definition of VA

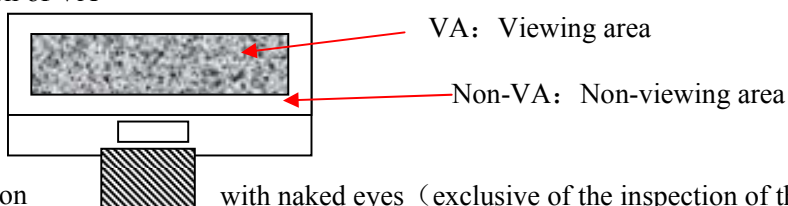

5.4 Inspection with naked eyes (exclusive of the inspection of the physical dimensions of defects carried out with magnifiers).

5.5 Electrical properties

Inspection with the test jigs against the product specifications or drawings; display contents and parameters shall conform to those of the product specifications and the display effect to the sample.

5.5.1 Test voltage (V) :



5.5.1.1 (Determined) according to the operating instruction of test jigs assuming the external circuit can be adjusted unless the customer otherwise specifies driving voltage(s). (Display) effects are controlled within the specified range of voltage variation (If no specific requirements, display effects are controlled at $V_{op} = 9V$ or $V_{op} \pm 0.3V$ when V_{op} is below 9V; if V_{op} is above 9V, display effects are controlled at $V_{op} \pm 0.3\%$ at least). For display products with the customer-specified fixed V_{op} , display effects are controlled by adjusting the internal circuit; if necessary, acceptable limit samples shall be built.

5.5.2 Current Consumption (I) : refer to approved product specifications or drawings.



6. Defects and Acceptance Standards

6.1 Dimensions: the outline dimensions and the dimensions that could influence the assembly at the customer's side shall conform to those on the approved drawings.

6.2 Main Defects – Functionality Tests:

No.	Item	Description	MAJ	MIN	Acceptance Criteria
6.2.1	Missing Segments	Missing segments or dots caused by broken contact(s), loose connection or an internal open circuit. 	√		Rejected
6.2.3	No display /Inaction	No segments, icons or graphics are displayed when the LCM is connected correctly.	√		Rejected
6.2.4	Mis-Display	Display pattern is deformed or jumbled-up under the normal scanning procedure.	√		Rejected
6.2.5	Wrong viewing angle	When powered up, the viewing angle at which the display is at its clearest is different from the required viewing angle or that of the approved samples.)	√		Rejected
6.2.6	Dim or Dark Display	Overall contrast is either too dark or too dim under normal operation.	√		If out of the voltage tolerance, Rejected
6.2.7	Slow response	Local response time varies when LCM is turned on or off.	√		Rejected
6.2.8	Extra segments, rows, or columns	Icons, traces, rows or columns that should not appear on the LCD screen and caused by LCD panel misalignment or insufficient corrosion.		√	Refer to dot/line standard
6.2.9	Dim segment	Under the normal voltage, the contrast of vertical and horizontal segments is uneven.		√	Reject or refer to samples

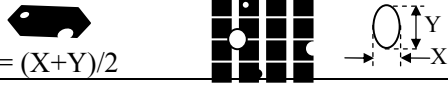

6.2.10	PI black/white spots	Partial black and white spots visible when changing display contents due to defective PI layer.		√	refer to the spot/line criteria for the visible spots when display image remains still; others OK.
6.2.11	pinhole/white spots	Deformed patterns appearing when LCD is turned on caused by missing ITO.  $d = (X+Y)/2$		√	refer to spot/line standard
6.2.12	Pattern distortion	Segment is either wider, narrower or deformed than the specified, caused by panel misalignment, resulting in unwanted heave(s) or missing. $ Ia-Ib < 1/4W$ (W is the normal width) 		√	Acceptable $ Ia-Ib > 1/4W$, rejected
6.2.13	High current	LCM current is larger than the designed value.		√	Rejected

6.3 LCD Visual Defects

6.3.1 Spot defect (defined within VA, spots out of VA do not count.)

Defect	Average diameter (d)	Acceptable quantity	MAJ	MIN
Spot defect (black spot, foreign matter, nick, scratches, including LC mis-orientation.)	$d \leq 0.2$	3		√
	$0.2 < d \leq 0.25$	2		
	$0.25 < d \leq 0.30$	1		

6.3.2 Line defects (defined within VA; those out of VA do not count.)

Defect	Length(L)	Width(W)	Acceptable quantity	MAJ	MIN
line defects (scratches, linear foreign matter) 	≤ 5.0	≤ 0.02	3		√
	≤ 3.0	≤ 0.03	3		
	≤ 3.0	≤ 0.05	1		

note: 1.If the width is bigger than 0.1mm, it shall be treated as spot defect.

6.3.3 Polarizer air bubble (defined within VA; those out of VA do not count.)

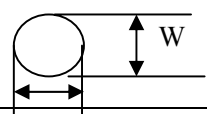
Defect	Average diameter (d)	Acceptable quantity	MAJ	MIN
Polarizer air bubble, Concave-Convex dot. 	$d \leq 0.3$	3		√
	$0.3 < d \leq 0.5$	2		
	$0.5 < d \leq 0.8$	1		



L	$d=(w+1)/2$			
---	-------------	--	--	--

6.3.4 Glass Damages (for LCMs without bezels and whose LCD edges exposed and for LCMs with bezels, including COG and H/S LCMs)

No.	Item	Acceptance Standard		MAJ	MIN
6.3.4.1	Chip on lead 		(mm)		√
		X	$\leq 1/8L$		
		Y	$\leq 1/3W$		
		Z	$\leq 1/2t$		
		Acceptable quantity	2		
		When $Y \leq 0.2\text{mm}$, the length of X doesn't count; for chip neither on lead nor through, when $X \leq 1/10L$, $Y \leq 1/2W$ max, it doesn't count.			
6.3.4.2	chip on corner(ITO lead) 		(mm)	MAJ	MIN
		X	Not entering into frame and not contacting with conductive position		√
		Y			
		Z	$\leq t$		
		Acceptable Quantity	2		
For chips on corners, refer to 6.3.4.3 and they must be out of the frame epoxy. For chips on lead, refer to 6.3.4.1					
6.3.4.3	Chip on sealed area (outer chip) 		(mm)	MAJ	MIN
		X	$\leq 1/8 L$		√
		Y	$\leq 1/2H$		
		z	$\leq 1/2t$		
		Accept numbers	2		
		The standard for inner chip on sealed area is the same as the standard for outer. For chip on the reverse of ITO contact pad ledge, refer to 6.3.4.1 for chip on the reverse of ITO contact pad ledge for the value of Y.			
Notes: T=Glass Thickness, L=Length, H=Distance between LCD Edge to Inside Edge of LCD Frame Epoxy and W=Width of Contact Pad Ledge.					

6.3.5 Others

No.	Item	Description	MAJ	MIN	Acceptance standard
6.3.5.1	Newton Ring /Background color	More than one color on the same LCD panel or different colors on different LCDs from the same batch.		√	Reject or refer to limit sample



6.3.5.2	LC Leakage	/	√		Rejected
6.3.5.3	Missing protective film	/		√	Rejected

6.4 Backlight

No.	Item	Description	MAJ	MIN	Accept standard
6.4.1	Backlight not working, wrong color	/	√		Rejected
6.4.2	Color deviation	When powered on, the LCD color differs from that of the sample and is found after testing not conforming to the drawing.		√	Refer to sample and drawing
6.4.3	Brightness deviation	When powered on, the LCD brightness differs from that of the sample and is found after testing not conforming to the drawing; or if conforming to the drawing but over±30%.		√	Refer to sample and drawing
6.4.4	Uneven brightness	When powered on, the LCD brightness is uneven on the same LCD and out of the specification of the drawing.		√	Refer to sample and drawing
6.4.5	Spot/line scratch	Appearance of spot or line scratches on the LCD when turned on.		√	Refer to 6.3.1/6.3.2

6.5 Metal frame (Metal Bezel)

No.	Item	Description	MAJ	MIN	Accept standard
6.5.1	Material/surface treatment	Metal frame/surface treatment do not conform to the specifications.	√		Rejected
6.5.2	Tab twist inconformity/ Tab not twisted	Wrong twist method or direction and twist tabs are not twisted as required.	√		Rejected
6.5.3	Oxidization, chapped paint, discoloration, dents, and scratches	Oxidation on the surface of the metal bezel; the quantity of spot defect (chapped front surface paint and substrate-exposing scratches) ≤0.8mm exceeds 3; the quantity of linear defects with the length ≤5.0mm and width ≤0.05mm exceeds 2; the quantity of spot defect (front dent, bubble, side surface chapped paint and substrate-exposing scratches) ≤1.0mm exceeds 3; the quantity of linear defects with the width ≤0.05mm exceeds 3.		√	Rejected
6.5.4	Burr	Burr(s) on metal bezel is so long as to get into viewing area.		√	Rejected

6.6 PCB/COB

No.	Item	Description	MAJ	MIN	Accept standard
6.6.1	Improper Epoxy Cover	1. Contacts exposure within the white circle for COB chip bonding. 2. The height of epoxy cover is out of the		√	Rejected



		<p>product specifications and drawing.</p> <ol style="list-style-type: none"> The epoxy cover over the COB chip exceeds the circle by more than 2mm in diameter, which is the maximum distance the epoxy cover is allowed to exceed the circle. Existence of obvious linear mark(s) or chip-exposing pinhole on the epoxy cover. The pinhole diameter on the epoxy over exceeds 0.25mm and there is foreign matter in the pinhole. 			
6.6.2	PCB cosmetic defect	<ol style="list-style-type: none"> Oxidized or contaminated gold fingers on PCB. Bubbles on PCB after reflow-soldering. Exposure of conductive copper foil caused by chapped or scratched solder-resist coating. <p>For the conductive area of PCB repaired with the solder resist coating material , the diameter ψ of the repaired area on the circuit must not exceed 1.3mm while for the non-conductive area of PCB repaired with the solder resist coating material, the diameter ψ must not exceed 2.6mm; the total number of repaired areas on PCB must be less than 10; otherwise, the PCB must be rejected.</p>		√	Rejected
6.6.3	Wrong or missing Components on PCB	<ol style="list-style-type: none"> Components on PCB are not the same as defined by drawing such as wrong, excessive, missing, or mis-polarized components. (The bias circuit of LCD voltage or the backlight current limiting resistance is not adjusted unless specified by the customer.) The JUMP short on PCB shall conform to the mechanical drawing. If excessive or missing soldering occurs, the PCB shall be rejected. For components particularly required by the customer and specified in the mechanical drawing and/or component specifications, their specifications must conform to those of the suppliers; otherwise they shall be rejected. 		√	Rejected

6.7 SMT (Refer to IPC-A-610C if not specified)

No.	Item	Description	MAJ	MIN	Accept standard
-----	------	-------------	-----	-----	-----------------



6.7.1	Soldering solder defects	Cold, false and missing soldering, solder crack and insufficient solder dissolution.		√	Rejected
6.7.2	Solder ball/splash	Solder ball/tin dross causing short at the solder point.		√	Rejected
6.7.3	DIP parts	Floated or tilted DIP parts, keypad, connectors.		√	Rejected
6.7.4	Solder shape	The welded spot should be concave and excessive or insufficient solder or solder burr on the welded spot must be rejected.		√	Rejected
6.7.5	Component pin exposure	For the DIP type components, 0.5~2mm component pin must be remained after cutting the soldered pin, and the solder surface should not be damaged nor should the component pin is fully covered with solder; otherwise rejected.		√	Reject
6.7.6	Poor Appearance	Caused by yellow-brown or black solder flux or resin or the white mist at the solder point caused by PCB cleaning.		√	reject

6.8 Heat Pressing (including H/S, FPC, etc.)

No.	Item	Description	MAJ	MIN	Acceptance standard
6.8.1	H/S or FPC out of specification		√		Rejected
6.8.2	Dimensions /position	Dimensions of heat compression material should be within the specification of the drawing and the contact of conductive material should cover more than 1/2 of ITO, PDA, etc and the dimensions of dislocation shall be within the tolerance.		√	Acceptable
6.8.3	Foreign Matter in Heat pressure area	If foreign matter in conductive heat compression area shall not cause short, it is OK. If foreign matter in non-conductive heat compression area does not exceed 50% of the heat pressure area, it is OK.		√	Acceptable
6.8.4	Folds			√	Refer to limited sample

6.9 Connectors and other components

No.	Item	Description	MAJ	MIN	Accept standard
6.9.1	Out of Specification	The specification of connector and other components do not conform to the drawing.	√		Rejected
6.9.2	Position and order	Solder position and Pin# 1 should be in the positions specified by the drawing.		√	Rejected



6.9.3	Cosmetic	1. Flux on PCB components and pins. 2. The pin width of a PIN connector exceeds ½ of the specified pin width.		√	Rejected
-------	----------	--	--	---	----------

6.10 General Appearance

No.	Item	Description	MAJ	MIN	Accept standard
6.10.1	Connection material	1. Damaged or contaminated FPC or H/S gold fingers or FFC contacts. 2. Sharp folds on FPC, FFC, COF, H/S (unless designed for). 3. Solder paste larger than 2/3 of pin width on the gold finger of FPC and PCB. 4. Pierced or folded FPC/FFC exceeding limit sample.		√	Rejected
6.10.2	Defective stiffener	Stiffener not fully covering H/S, FFC, or FPC and or not pasted on or glued on output pins.		√	Rejected
6.10.3	Surface dirt	Smears, residual glue, finger prints, etc. on the surface of finished LCMs; solder spatters or solder balls on non-soldered area of PCB/COB. Non-removed defect mark or label on LCMs.		√	Rejected
6.10.4	Assembly black spot	Smears or black spots found on LCMs after backlight or diffuser are assembled.		√	Refer to 6.3.1
6.10.5	Product mark	Missing, unclear, incorrect, or misplaced part numbers and/or batch marks.		√	Rejected
6.10.6	Inner packing	Packing being inconsistent with quantity and part number on packing label, specifications or the customer order - either short-packed or over-packed.		√	Rejected

7. Reliability test

Notes: ①Reliability tests shall be done as required by the customer if they inform ADV of their special requirements when starting a project.

②Storage test at high-low temperature and functionality test shall be done with reference to the specified temperature range.

③Test conditions shall be controlled at the permissible tolerance of ±5°C.



8. Packing

- 8.1 Product packing shall be checked and qualified in accordance with design requirements for packing. The product packaging label shall bear not only product name, part number, quantity, product date code but also QA's qualifying stamp for each production stage. Incomplete or wrong label shall be unacceptable.
- 8.2 When there are problems with packing safety conformity such as shock resistance, moisture resistance, anti ESD and pressure resistance, packing shall be disqualified.
- 8.3 When confirmed and accepted by AVD, packing shall be inspected and released according to the customer's special requirements for packing.
- 8.4 RoHS and non-RoHS compliant products shall be labeled clearly and separately. Unless otherwise specified by the customer, "RoHS" labels shall be used for all RoHS compliant products.

9. Others

- 9.1 Items not specified in this document or released on compromise should be inspected with reference to

Test item	Condition	Time(hrs)	Acceptance standard
High Storage Temp.	80°C	120	Functions and appearance are qualified before and after test
High Operating Temp.	70°C	120	
Low Storage Temp.	-30°C	120	
Low Operating Temp.	-20°C	120	
Temp& Humidity Test	40°C/ 90%RH	120	
Thermal Shock	-20°C ← 25°C → +70°C (30 min ← 5 min → 30min)	10 cycles	

the mutual agreement and limit samples.